

On the Seismic Performance of Superlong Cable-Stayed Bridges

A.S. Nazmy¹

ABSTRACT

The seismic behavior of contemporary superlong-span cable-stayed bridges is investigated. The recent trend of increasing the center-span length of these bridges has given rise to several problems such as excessive cable sag and high compression in the bridge girders and towers. This study addresses these problems in light of the highly nonlinear behavior of such very long-span bridges under seismic loads, and sheds some light on their possible solutions. A three-dimensional 1000 meter center-span analytical model of a modern cable-stayed bridge (CSB) is investigated under the effect of earthquake excitation using nonlinear time-history analysis. The analytical model used in this study is based on recent practical designs of very long-span cable-stayed bridges. Effects of spatial variability of ground motion are included in the study. The use of fiber-reinforced plastics for the stay cables is evaluated. The use of longitudinal cable restrainers between the bridge girder and towers, as elastic dampers, to reduce seismic forces is also investigated. Furthermore, the effect of adding stiffening ropes on improving the dynamic characteristics of the cable system is studied. Recommendations for the selection of tower configuration, cable arrangement, and girder cross-section for such superlong cable-stayed bridges are provided. The study indicates that cable-stayed bridges can still be economical for spans up to 1000 meters and beyond, being a competitive substitution for suspension bridges.

INTRODUCTION

Cable-stayed bridges are now entering a new era as superlong bridges. The Normandie Bridge on the River Seine in France, which has a center-span length of 856 meters, has already been open to traffic since the fall of 1994, while the Tatara Bridge in Japan, with 890 meter long center-span, is currently under construction. However, for this bridge type with such extremely long spans the behavior becomes highly nonlinear under dead load, live load and environmental loads. Nonlinearity can be due to changes in the overall bridge geometry due to finite deformations, change in cable sag due to tension changes, and the interaction between the bending moments and large axial compression in the bridge tower and girder elements. Nazmy and Abdel-Ghaffar (1987 and 1990b) showed that large geometric nonlinearity was observed in the seismic performance of a 670-m (2200-ft) span cable-stayed bridge model due to large variation in cable sag during seismic excitation. Large seismic energy is also transferred between the bridge deck and towers producing large moments and shear forces at the bases of the bridge towers. Since most of Japan and several parts of the United States where superlong CSBs could potentially be built are experiencing numerous seismic events, it becomes essential to examine carefully the seismic behavior of CSBs for the new range of span lengths. It is therefore the objective of this study to

¹Associate Professor, Department of Civil and Environmental Engineering, University of Maine, 5711 Boardman Hall, Orono, ME 04469-5711, USA.

investigate different possible solutions for the problem of large nonlinearity experienced in the contemporary superlong-span cable-stayed bridges when subjected to multiple-support excitation.

THE ANALYTICAL MODEL

In this study, a theoretical model of a 1000-m center-span cable-stayed bridge (Fig. 1) is developed based on the recently published literature on the Normandie Bridge (Virlogeux 1994) and the Tataru Bridge (Ito and Endo 1994). In developing the model, several practical seismic design considerations were taken into account based on reviewing various designs of recent long-span cable-stayed bridges.

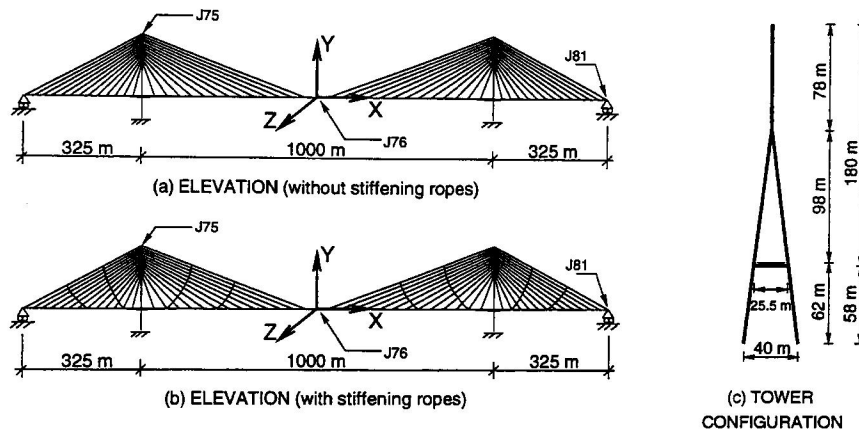

Figure 1. The analytical model.

For the tower-deck connection, elastic links were assumed between the tower and the deck in the lateral direction to prevent excessive lateral displacement of the deck that could occur in a loose or "floating" connection. These elastic links, which could be cables, links, or rubber blocks, reduce also the lateral force transmitted between the deck and towers during earthquakes when compared to rigid links. In the longitudinal direction, floating girders on the towers and abutments were assumed, representing the new trend in cable-stayed bridge design since rigid connection could develop large moment and shear in the towers in that direction. However, due to the possibility of having large longitudinal displacement of the girder during earthquakes, elastic cable restrainers between the bridge girder and towers were used in an alternative design to examine their effectiveness. The natural period of the bridge longitudinal vibration could be controlled by changing the stiffness of these elastic restrainers (Sakai 1985). Elastic springs were also assumed between the girders and the towers in the vertical direction.

To provide the large torsional rigidity needed for aerodynamic stability and for supporting the transverse seismic loads, a streamlined box section for the bridge girder similar to that used in suspension bridge designs, along with an inverted Y-shape tower (see Fig. 1-c) similar to that used in the Normandie Bridge (Virlogeux 1994), were chosen. Other possible tower shapes are the A-shape, the diamond-shape, and the delta-shape. The towers are rigidly fixed to the piers.

A multi-cable system, in which the deck is suspended by closely-spaced cables, was chosen for the present study. This system maintains a small girder depth even for long center-spans. Although the bridge redundancy increases with the increased number of cables, which makes the girder develop large pseudo-static forces under multiple-support excitation, it was noticed that these forces decreased as the bridge span increased (Nazmy and Abdel-Ghaffar 1992). Stiffening ropes connecting all stay cables together to dampen wind-induced vibrations and reduce the sag effect, which is a main source of geometric nonlinearity in cable-stayed bridges, were considered in an alternative design (see Fig. 1-b).

NONLINEAR DYNAMIC ANALYSIS UNDER MULTIPLE-SUPPORT EXCITATION

The equations of motion of the three-dimensional vibration of a long-span cable-stayed bridge when subjected to multiple-support excitation at its two anchor piers and two tower bases, can be expressed in terms of the partitioned mass [M], damping [C], and stiffness [K] matrices as follows (Nazmy and Abdel-Ghaffar 1987 and 1990a; Clough and Penzien 1993)

$$\begin{bmatrix} M_{ss} & M_{sg} \\ M_{gs} & M_{gg} \end{bmatrix} \begin{Bmatrix} \ddot{u}_s \\ \ddot{u}_g \end{Bmatrix} + \begin{bmatrix} C_{ss} & C_{sg} \\ C_{gs} & C_{gg} \end{bmatrix} \begin{Bmatrix} \dot{u}_s \\ \dot{u}_g \end{Bmatrix} + \begin{bmatrix} K_{ss} & K_{sg} \\ K_{gs} & K_{gg} \end{bmatrix} \begin{Bmatrix} u_s \\ u_g \end{Bmatrix} = \begin{Bmatrix} 0 \\ 0 \end{Bmatrix} \quad (1)$$

where {u} denotes the total dynamic displacement vector; the subscript "g" denotes the degrees of freedom corresponding to the points of application and directions of ground motion; and the subscript "s" denotes all other degrees of freedom of the bridge model.

The total nodal displacements may be decomposed into pseudo-static displacements (subscript "p") and vibrational displacements (subscript "v") as follows:

$$\begin{Bmatrix} u_s \\ u_g \end{Bmatrix} = \begin{Bmatrix} u_{ps} \\ u_{pg} \end{Bmatrix} + \begin{Bmatrix} u_{vs} \\ 0 \end{Bmatrix} \quad (2)$$

Eq. (1) can be solved for linear analysis using modal superposition, where the modes of vibration are computed using the tangent stiffness matrix of the bridge in the dead-load deformed state (Nazmy and Abdel-Ghaffar 1987). In the present study, the first 30 natural modes were computed and utilized in the modal analysis. The solution of Eq. (1) for nonlinear seismic analysis was performed using a tangent stiffness iterative procedure and step-by-step integration technique. The bridge was discretized in space into finite elements, mainly beam-column and cable elements, and the Wilson- θ method was used for the time discretization. The incremental equations of motion were integrated in the modal coordinate space, using the normal mode shapes as an orthogonal basis for coordinate transformation. This approach takes much less computational time than integration in the real displacement coordinate space. For complete description of the nonlinear analysis procedure and algorithm see Nazmy and Abdel-Ghaffar (1990a)

EARTHQUAKE- INPUT MOTIONS

Due to the extended length of the bridge model under investigation, it became more realistic to assume spatially-varying ground motion for inputs at the four supports along the bridge (Nazmy and Abdel-Ghaffar 1992). Existing strong motion records can be used to define such multiple-support seismic input. In the present study, some of the ground motion records taken from the Imperial Valley,

CA, (El Centro) earthquake of October 15, 1979 were employed to define the multiple input (Nazmy and Abdel-Ghaffar 1987). The displacements of these records have very strong components at periods close to the fundamental periods of the investigated model, and the ground accelerations of these records are rich in high frequency components. Three orthogonal components of the seismic records were applied simultaneously at the tower bases, while two components (in the vertical and lateral directions) were applied at the two abutments at the same time.

EARTHQUAKE RESPONSE

To investigate the effectiveness of different alternatives proposed in this study for improving the seismic performance of superlong-span CSBs, the nonlinear seismic analysis of the bridge model shown in Fig. (1) when subjected to multiple-support excitation was performed for four different cases:

case 1: A floating bridge girder in the longitudinal direction without any connection between the deck and the towers or the abutments in that direction. Vertical springs and lateral elastic links are used between the deck and the towers. Conventional steel cables (CSC) are used in this case. This case represents the modern trend in cable-stayed bridge design (Figure 1-a).

case 2: Similar to case 1, but with using elastic cable restrainers between the girder and the towers in the longitudinal direction. The spring coefficient of these restrainers is 120 MN/m per girder per tower. These elastic restrainers are likely to reduce the longitudinal movement of the bridge deck during earthquakes. They also reduce seismic forces in the towers when compared to rigid links.

case 3: Similar to case 1, but with using carbon fiber composite cables (CFCC). The light weight, high strength, and corrosion resistance of fiber-reinforced plastics are making them more popular in CSB construction. Due to their light weight, CFCC are expected to have much less sag than CSC when used in CSBs as stay cables (Khalifa 1992). The unit weight for CFCC is 15 kN/m³, while for CSC it is 78 kN/m³. At the same time, both tensile strength and tensile modulus of carbon composites are as high as those for steel strands (Tokyo Rope Manufacturing Company 1989).

case 4: Similar to case 1, and adding stiffening ropes connecting the stay cables together as shown in Figure (1-b). All cables and stiffening ropes are CSC. These ropes are usually used to dampen wind-induced vibrations and reduce the sag effect, which is a main source of nonlinearity in CSBs. Therefore, it is anticipated that less nonlinearity will be observed in the seismic behavior.

Free Vibration Characteristics

Fig. (2) shows the first 12 modes of free vibration of the 3-D model used in this study for case 1. A strong coupling (such as lateral-torsion or bending-long.) in the three orthogonal directions within some of the mode shapes can be observed in this figure. The close spacing of the natural frequencies is another feature that can also be observed. This three-dimensionality and modal coupling in the dynamic behavior of CSBs cannot be captured in any two-dimensional analysis, justifying the need for 3-D analysis. Table (1) lists the natural frequencies of the first 15 modes of vibration for cases 1-3. Case 4, where the stiffening ropes divided each cable into sub-elements, experienced several pure cable modes that showed up in-between the modes of the previous 3 cases, and therefore is not listed in that table.

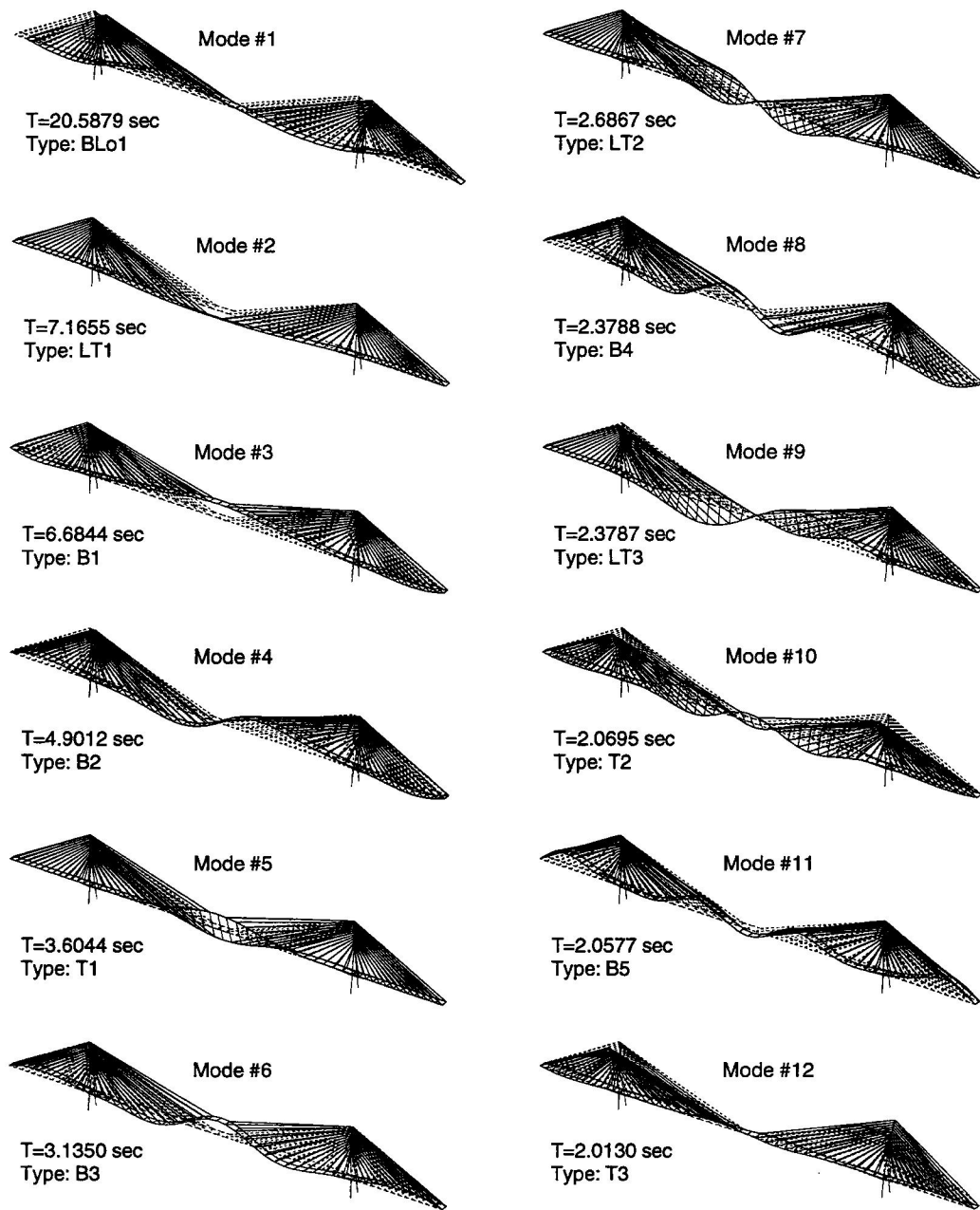

Figure 2. The first 12 computed 3-D mode shapes for case 1.
 B=bending, L=lateral, T=torsional, Lo=longitudinal.

Table 1. Natural frequencies of the first 15 modes of vibration for cases 1-3.

Mode No.	Case 1		Case 2		Case 3	
	Period (sec.)	Mode type*	Period (sec.)	Mode type*	Period (sec.)	Mode type*
1	20.5879	BLo1	6.8701	LT1	16.7596	BLo1
2	7.1655	LT1	6.3537	B1	6.5676	LT1
3	6.6844	B1	4.7239	B2	5.6165	B1
4	4.9012	B2	3.5649	T1	4.2367	B2
5	3.6044	T1	2.9304	B3	2.6887	T1
6	3.1350	B3	2.6480	LT2	2.5719	B3
7	2.6867	LT2	2.5530	BLo1	2.4608	LT2
8	2.3788	B4	2.3605	LT3	2.0640	LT3
9	2.3787	LT3	2.1185	B4	2.0305	B4
10	2.0695	T2	2.0308	T2	1.7944	B5
11	2.0577	B5	1.9673	T3	1.7777	T2
12	2.0130	T3	1.9672	B5	1.6801	B6
13	1.9735	T4	1.9389	T4	1.6172	T3
14	1.8847	B6	1.8267	B6	1.6170	T4
15	1.6663	B7	1.6090	B7	1.4967	B7

* B=bending, L=lateral, T=torsional, Lo=longitudinal, LT=coupled L&T, BLo=coupled B&Lo.

Seismic Performance

The response displacements and member forces for selected joints and members were observed in this investigation to evaluate the seismic performance of the bridge model for the above listed four alternative cases. The chosen displacements were the longitudinal displacement at the left tower top (J75), the vertical and lateral displacements at the girder midspan (J76), and the longitudinal movement of the bridge deck at the right abutment (J81); see Figure (1). The shearing forces and bending moments at the base of the left tower in the longitudinal direction were also observed. For displacements, only the vibrational response was considered, while for member forces the total (vibrational plus pseudo-static) response was examined. Figure (3) shows a comparison between the linear and nonlinear seismic responses for case 1, for some response quantities. It can be noticed in this figure that a very large nonlinearity is present in this superlong-span floating system. The longitudinal displacement at the right abutment (J81) has increased by 89% (relative to the linear response) and at the left tower top (J75) by 34%, while the vertical displacement of the girder at midspan (J76) has decreased by 17% and the bending moment at the base of the left tower has increased by 27%.

Table (2) summarizes the results of the linear (L) and nonlinear (NL) analyses for all four cases. The response displacements in this table are the absolute maximum vibrational displacements at the joints, while the response moment/shear are the absolute maximum total longitudinal bending moment and shear force at the base of the left tower. It can be noticed in this table, as noticed before in Fig. (3), that the floating system with CSC, case 1, experienced a large nonlinearity under seismic loads. The use of longitudinal elastic cable restrainers between the tower and the deck, case 2, has greatly decreased the level of nonlinearity (the percentage difference between linear and nonlinear seismic responses), and slightly reduced the NL longitudinal displacement at the abutment (J81). However, these restrainers greatly increased both the longitudinal bending moments and shear forces in the towers. Therefore, their usage does not seem to be advantageous. The use of CFCC, case 3, has also reduced the degree of nonlinearity for all response quantities when compared to case 1, and considerably reduced the

longitudinal displacement at the abutment from 50.1 to 33.1 cms. However, it increased all other response quantities due to an increased cable stiffness. Finally, although the stiffening ropes (case 4) reduced the nonlinearity for all response quantities and considerably reduced the longitudinal displacement at the abutment, they increased the moment and shear in the towers.

Table 2. Linear (L) and nonlinear (NL) seismic responses* for the 4 cases studied.

Response Quantity	x-displ. at joint J75		y-displ. at joint J76		z-displ. at joint J76		x-displ. at joint J81		Long. S.F. at left tower base		Long. B.M. at left tower base	
	L	NL	L	NL	L	NL	L	NL	L	NL	L	NL
Case 1	33.7	45.1	65.9	54.6	153	155	26.5	50.1	2.19	2.25	216	274
Case 2	57.3	56.2	81.8	60.4	162	163	48.1	47.8	30.7	30.1	1504	1450
Case 3	45.3	59.5	74.2	72.9	174	174	27.8	33.1	2.62	2.91	316	375
Case 4	41.3	43.3	65.7	60.6	155	157	30.4	34.6	2.32	2.79	293	321

* response displacements are in cm, shear forces are in MN, and bending moments are in MN-m.

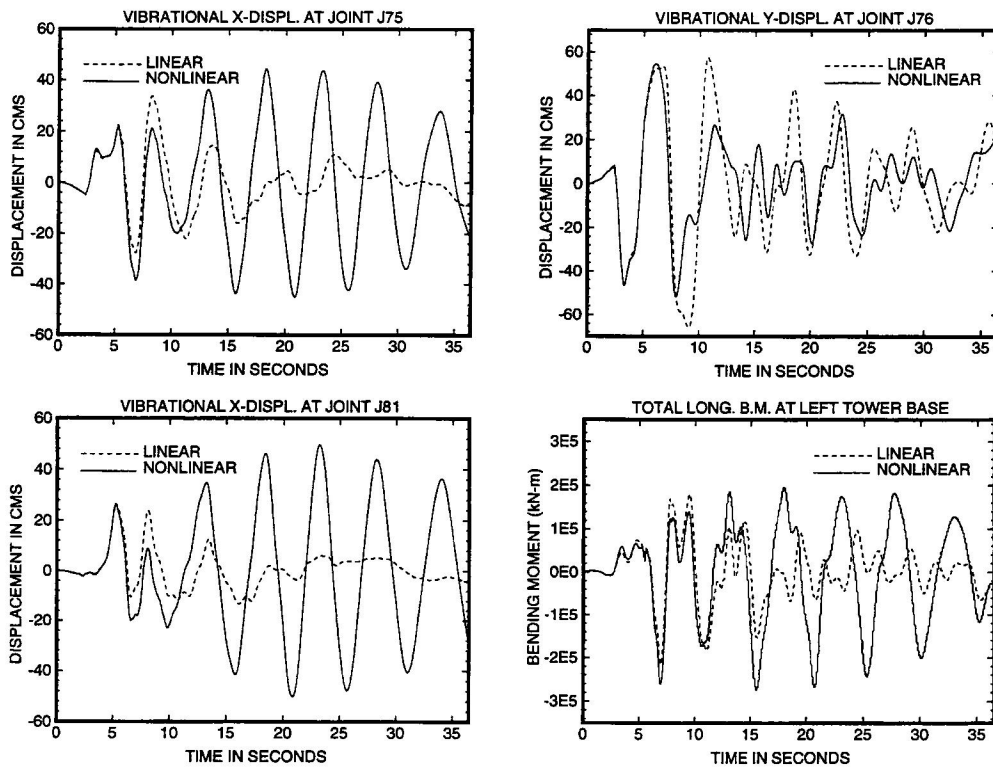

Figure 3. Comparison between linear and nonlinear seismic responses for case 1.

It appears from the above discussion that none of the three alternatives (cases 2, 3, and 4) has a clear advantage over the basic system (case 1) with regard to seismic performance. Although the floating system with CSC and no stiffening ropes undergoes larger deck movement in the longitudinal direction, it provides the least member forces in the bridge towers, as well as the least vertical and lateral displacements of the bridge deck and the least longitudinal displacement at the tower tops.

CONCLUSIONS

1. The seismic behavior of superlong-span CSBs indicates a high degree of geometric nonlinearity, especially when the bridge deck is floating on all supports in the longitudinal direction.
2. Although the use of carbon fiber composite cables, stiffening ropes, or longitudinal cable restrainers between the deck and towers reduced the level of nonlinearity, the member forces and joint displacements, except the longitudinal movement of the bridge deck, have increased.
3. It is recommended to use longitudinally floating system for superlong-span cable-stayed bridges (center span ≥ 1000 meters). However, the analysis type should be given a special attention since a linear seismic-response analysis will considerably underestimate the response quantities. The longitudinal movement of the bridge deck for this system is still within an acceptable range.
4. There is strong coupling in the three orthogonal directions within several modes of vibration, which requires a three-dimensional dynamic analysis to capture its effect on the seismic response.

REFERENCES

- Clough, R. W., and Penzien, J. (1993). *Dynamics of Structures, 2nd ed.*, McGraw-Hill, New York, N.Y.
- Ito, M., and Endo, T. (1994). "The Tataru Bridge - World's Longest Cable-Stayed Span." *Structures Congress XII, Vol. 1, Proc. of ASCE Structures Congress'94, Atlanta, GA, April 24-28*, 677-682.
- Khalifa, M. A. (1992). "Dynamic Vibration of Cable-Stayed Bridges Using Carbon Fibre Composite Cables." *Proc. of the 1st Int. Conf. on Advanced Composite Materials in Bridges and Structures, Sherbrooke, Québec, Canada*, 465-477
- Nazmy, A. S., and Abdel-Ghaffar, A. M. (1987). "Seismic Response Analysis of Cable-Stayed Bridges Subjected to Uniform and Multiple-Support Excitations." *Report No. 87-SM-1, Dept. of Civil Engrg., Princeton University, Princeton, NJ*.
- Nazmy, A. S., and Abdel-Ghaffar, A. M. (1990a). "Non-Linear Earthquake-Response Analysis of Long-Span Cable-Stayed Bridges: Theory." *Earthquake Eng. and Struc. Dynamics*, Vol. 19, No. 1, 45-62.
- Nazmy, A. S., and Abdel-Ghaffar, A. M. (1990b). "Non-Linear Earthquake-Response Analysis of Long-Span Cable-Stayed Bridges: Applications." *Earthquake Eng. and Struc. Dyn.*, Vol. 19, No. 1, 63-76.
- Nazmy, A. S., and Abdel-Ghaffar, A. M. (1992). "Effects of Ground Motion Spatial Variability on the Response of Cable-Stayed Bridges." *Earthquake Eng. and Struc. Dynamics*, Vol. 21, No. 1, 1-20.
- Sakai, F. (1985). "Some Considerations on Long-period Waves in Earthquake Engineering." *Proc. of the PRC-US-Japan Trilateral Workshop on Engrg. for Multiple Natural Hazard Mitigation, Beijing, China, Jan. 7-12, E.5.1-E.5.16*.
- Tokyo Rope Manufacturing Company, Ltd. (1989). *Carbon Fiber Composite Cable Technical Data*.
- Virlogeux, M. (1994). "The Normandie Bridge." *Structures Congress XII, Vol. 1, Proc. of the ASCE Structures Congress'94, Atlanta, GA, April 24-28*, 660-665.